

ENVIRO-SAFE HIGH CAPACITY ROUND GRATE INLET SKIMMER  
BOX SYSTEM FOR USE UNDER MANHOLES

ROUND GISB FOR MOUNTING UNDER MANHOLE

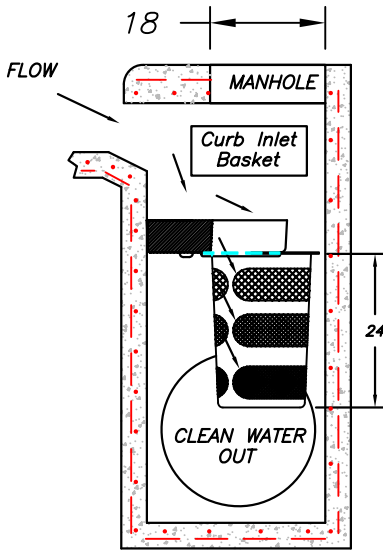
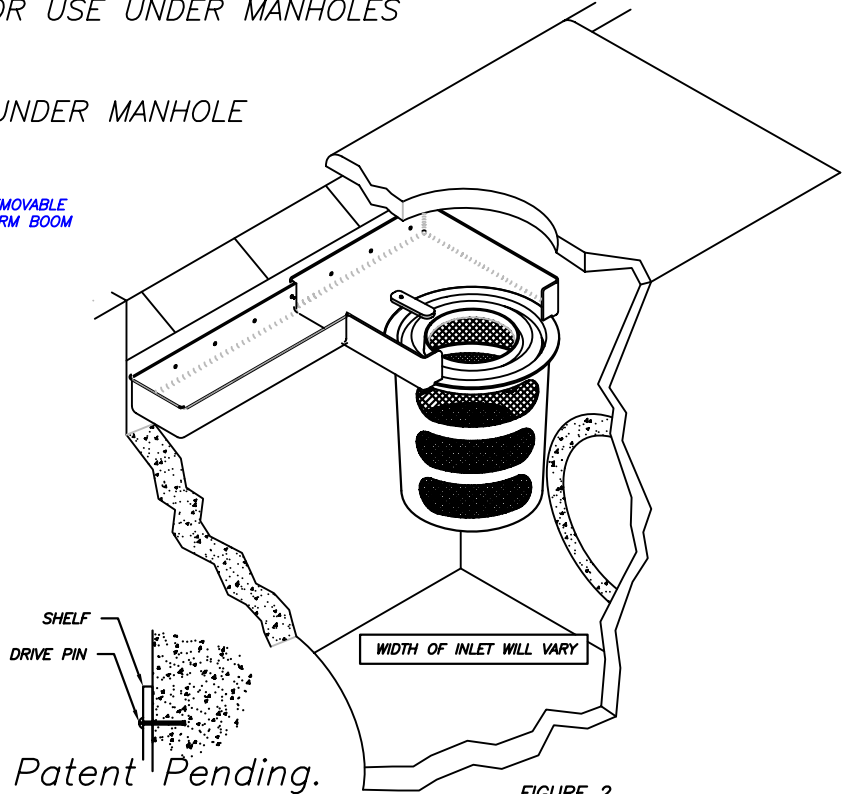
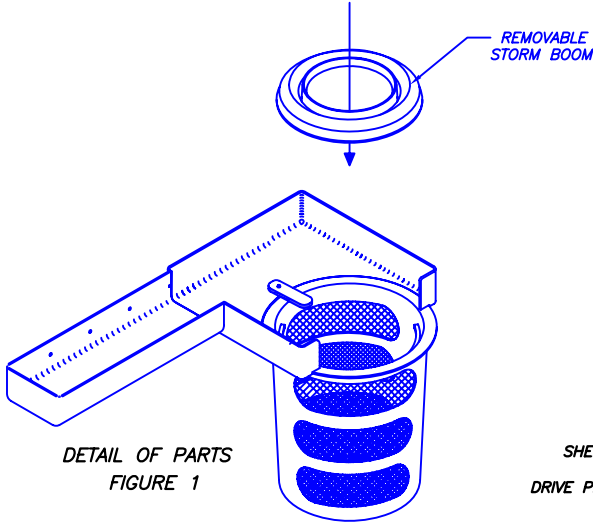

FLOW RATES				
	$Q = SO * c_d * A \sqrt{2 * g * h}$ $c_d = \text{Coefficient of Discharge} = .67$			
	SO	A (ft <sup>2</sup> )	h (ft)	Q (ft <sup>3</sup> /s)
TOP SIDE	1	.61	.45	2.10
CENTER SIDE	.62	.59	.95	1.90
BOTTOM SIDE	.56	.57	1.45	2.00
BOTTOM	.68	.28	1.73	.68
TOTAL				6.68

NOTES:

1. SHELF SYSTEM PROVIDES FOR ENTIRE COVERAGE OF INLET OPENING SO TO DIVERT ALL FLOW TO BASKET.
2. SHELF SYSTEM MANUFACTURED FROM MARINE GRADE FIBERGLASS, GEL COATED FOR UV PROTECTION.
3. SHELF SYSTEM ATTACHED TO THE CATCH BASIN WITH NON-CORROSIVE HARDWARE.
4. FILTRATION BASKET STRUCTURE MANUFACTURED OF MARINE GRADE FIBERGLASS, GEL COATED FOR UV PROTECTION.
5. FILTRATION BASKET FINE SCREEN AND COARSE CONTAINMENT SCREEN MANUFACTURED FROM STAINLESS STEEL.
6. FILTRATION BASKET HOLDS BOOM OF ABSORBENT MEDIA TO CAPTURE HYDROCARBONS. BOOM IS EASILY REPLACED WITHOUT REMOVING MOUNTING HARDWARE.
7. FILTRATION BASKET LOCATION IS DIRECTLY UNDER MANHOLE FOR EASY MAINTENANCE.

REMOVABLE BASKET CATCHES EVERYTHING  
AND MAY BE REMOVED THROUGH MANHOLE  
WITHOUT ENTRY.

5 YEAR MANUFACTURERS WARRANTY

PATENTED

ALL FILTER SCREENS ARE STAINLESS STEEL

SUNTREE QUALITY PRODUCTS ARE BUILT FOR EASY CLEANING AND ARE  
DESIGNED TO BE PERMANENT INFRASTRUCTURE AND SHOULD  
LAST FOR DECADES.

SUNTREE TECHNOLOGIES 798 CLEARLAKE RD. SUITE #2 COCOA FL. 32922 TEL. 321-637-7552 FAX 321-637-7554		PROJECT: 16" Manhole Cover	
16" CURB INLET BASKET SYSTEM		REVISIONS:	DATE:
DATE: 12/02/05	SCALE: SF = 15	REVISIONS:	DATE:
DRAFTER: N.R.B.	UNITS = INCHES	REVISIONS:	DATE: